

Envelop Tracking and Measurement

XING Rongxin^{1,2}, WANG Han^{1,2}, HU Yurong², WEI Liang²,
CHEN Xiaosong², WU Yongming²

(1. *China Electronics Standardization Institute, Beijing 100176, China;*

2. *Shenzhen CESI Information Technology Co., Ltd, Shenzhen 518052, China*)

Abstract: Power consumption is a vital issue for communication systems, especially for those which powered by batteries. In wireless communication system, the power consumption of PA (power amplifier) consumes a large portion of power compared with another component. How to reduce the power consumption of PA is always one of the big topics in the R&D and application of PA. Modern communication systems which have the high Peak to Average Power Ratio (PAPR). Envelope tracking technology can effectively reduce the power consumption of PA, especially for the high PAPR system. In the meantime, ET does not affect the performance of PA and communication system. This paper introduces the principle of ET, and gives the test method of ET performance. An ET test system has been built using R&S SMW 200A vector signal generator and FSW vector signal analyzer. The measurement result shows 20% of power saving by the application of ET.

Key words: Envelope Tracking (ET), 5G, Vector Generator, Vector Analyzer

1 Introduction

Power amplifiers (PAs) are vital components of communication system. The function PA is to amplify the amplitude of input RF signal and to improve the performance of impedance matching. PA is the key component of 5G, Wi-Fi, LTE and other wireless communication systems. Fig.1 shows a scheme of a typical wireless communication system. There are several to dozens of PAs in one single communication system. The performance of PA, such as operation frequency, gain, power added efficiency (PAE), saturation power, 1dB compression point and third-order inter-modulation, directly affect the communication performance of wireless communication system.

Power consumption is critical to communication system, especially for those powered by battery. PAs consume the most power of the communication system. Therefore, PAE of PA directly affects the power efficiency of the communication system. Bad PAE per-

formance of PA can reduce the standby time of system. And generate more heat which may cause malfunction of system, even burn down the system.

How to improve the PAE performance and reduce the power consumption is one of the biggest issues for the development and application of PA. Several techniques have been utilized, such as envelope tracking (ET), Digital Pre-distortion (DPD), etc. ET technology can greatly reduce the power consumption of PA and communication system without reducing the performance of communication, especially for those which has high Peak to Average Power Ratio (PAPR). This paper introduces the principle of envelope tracking of PA, and gives the test method of envelope tracking performance.

2 Principle of ET

To improve the utilization of spectrum, complex high-order modulation and multiplexing are widely used in communication systems. However, that may

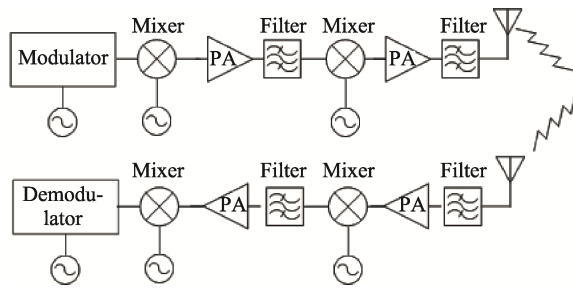

Fig.1 Scheme of typical wireless communication system

introduce a relatively high PAPR to the output signal of PA. In order to ensure the gain linearity of PA, it is necessary to set the PA working in the fallback zone, that can inevitably reduce the PAE of PA. PA with ET capacity can adjust the power supply voltage according to the amplitude of the input RF signal. Fig.2 shows the principal of ET. The envelope tracking system, including envelope detector, power modulator and power amplifier. The envelope signal is generated as the RF signal is detected. The envelope signal is amplified by the power modulator and then input to the power amplifier as the power signal to PA. At the same time, the envelope signal and the RF signal of the input power amplifier must be fully synchronized and aligned. The delay timer is adjustable according to the delay of Envelop Detector, Power Modulator and Power Amplifier. Through this mechanism, the output voltage of DC power supply is changed proportional to the amplitude of input RF signal simultaneously.

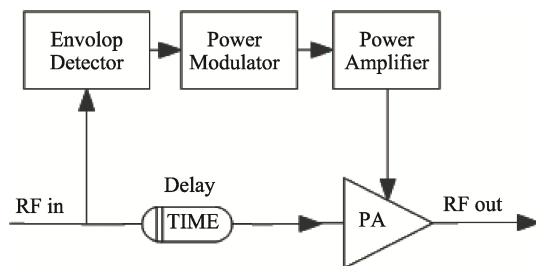

Fig.2 Principal of ET

Fig.3 illustrates the comparison of PA output with and without ET. The grey part in Fig.3 is the energy consumed as heating, the dark part is the useful RF signal transmitted finally. As shown in the left part of

Fig.3, which stands for PA without ET, a large portion of energy is consumed for heating. While in the right part which stands for PA with ET, only a small part of energy is consumed by heating. Obviously, the function of ET improves the energy efficiency of PAs dramatically. With the function of ET, the higher ratio of peak to average, the more energy can be saved for PAs. ET is more and more popular for PA design and application.

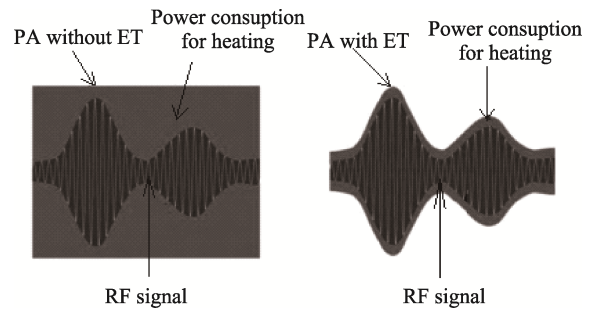

Fig.3 Comparison of PA output with and without ET

3 Measuring the ET of PAs

Envelope tracking test system includes vector signal generator, vector signal analyzer, DC power supply and DC tropper. Depends on the structure of PA under test, the DC tropper may be a built-in part of PA, or it may be an independent device as part of the test system. Fig.4 shows a typical test setup of ET. In the test system, the vector signal analyzer and vector signal generator shall be able to support ET testing function. During ET testing, the signal generator transmits the RF signal to be amplified to the input of the PA under test, and simultaneously sends the amplitude of modulation signal ($\sqrt{I^2 + Q^2}$) to the DC tropper. DC tropper modulates DC power to PA according to the amplitude of modulation signal. The function of signal analyzer is to measure the quality of modulation signal (such as EVM, ACLR, etc.) and calculate the PEA of PA under test. The LAN between the signal generator and signal analyzer is to transmit the modulation signal to ensure that the signal generator and signal analyzer process the same modulated signal and amplitude. If the quality

of modulated signal is not acceptable, the parameters of ET test needs to be modified. There are three ways to adjust DC power supply by the amplitude of modulated signal: linear, polynomial and look-up table mode.

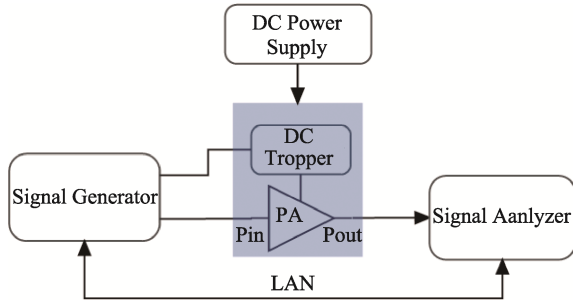

Fig.4 ET test setup

4 Measurement Results

A power amplifier is tested by the method illustrated in part 3. R&S SMW 200A vector signal generator with option k-540 and FSW vector signal analyzer with option B71 can be used. The ET test setup with SMW200A and FSW is illustrated in Fig.5.

The vector signal generator SMW200A can provide the RF signal and envelope signal (I and Q) for PA under test. The vector signal analyzer FSW can measure the RF signal output from PA, and the voltage and current of the output by the DC modulator. The test procedure and control of DC power supply manipulated by SMW200A. The alignment of power envelope signal and RF input signal of power amplifier is very important for the ET measurement. In order to achieve synchronization, RF signal and envelope signal must have the common clock reference, and the vector signal

generator must have delay time calibrated. The communication between the SMW200A and FSW is via LAN. The DC modulator is controlled by SMW200A through the interface called eTrak which standardized by the MIPI Alliance.

There are three steps to set up the ET measurement by the software run on SMW200A. The first step is to set the voltage of envelope and DC modulator, such as V_{MAX} , V_{MIN} , Bias and Offset, etc. (Shown as Fig.6); The second step is set the parameters of envelope shaping and delay (Shown as Fig.7); The last step is to set the shaping mode (Shown as Fig.8). The shaping mode can be linear, look up table, polynomial or detroughing.

In the process of ET measurement, the signal analyzer measures the output power from the PA under test and the input DC power to the PA. The PAE of PA can be calculated by Formula 1.

$$\eta_{add} = \frac{P_{out} - P_{in}}{P_{DC}} \quad (1)$$

Where η_{add} is the PEA of PA, P_{out} is the output power of PA, P_{in} is the input power to PA, P_{DC} is the input DC power to PA. By comparing the PEA of PA under test with and without the ET, the performance of ET can be evaluated.

According to the above method, the ET performance of an amplifier has been measured. Fig.9 shows the measurement results. The results show that the PAE of the tested PA with ET is improved by nearly 20% compared with that without ET. In the meantime, the signal quality of PA is not be deteriorated, such as EVM, AM/AM and AM/PM.

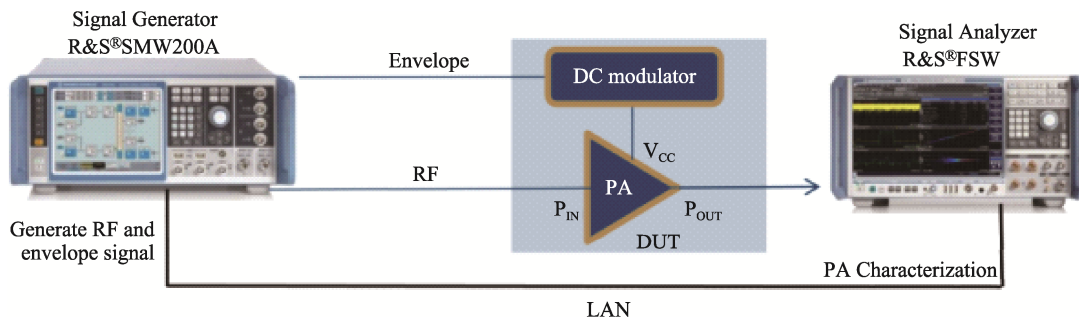

Fig.5 ET measurement with SMW200A and FSW

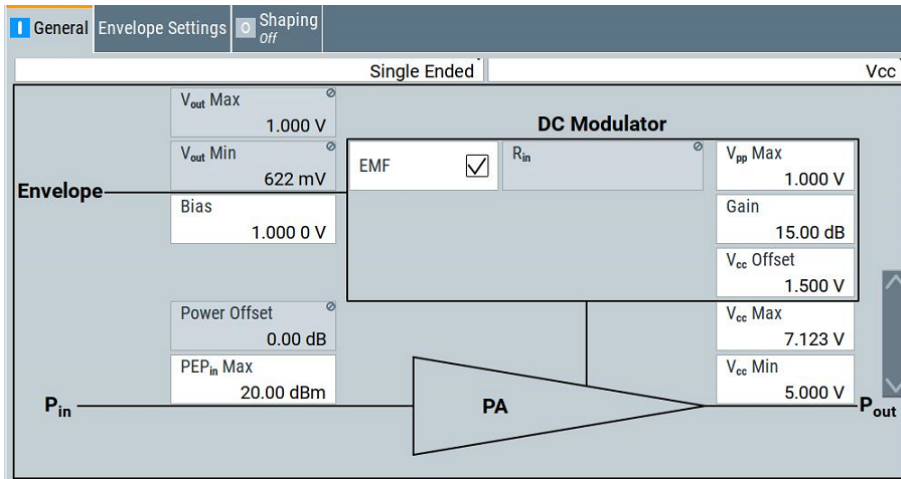

Fig.6 Voltage Setting for ET measurement

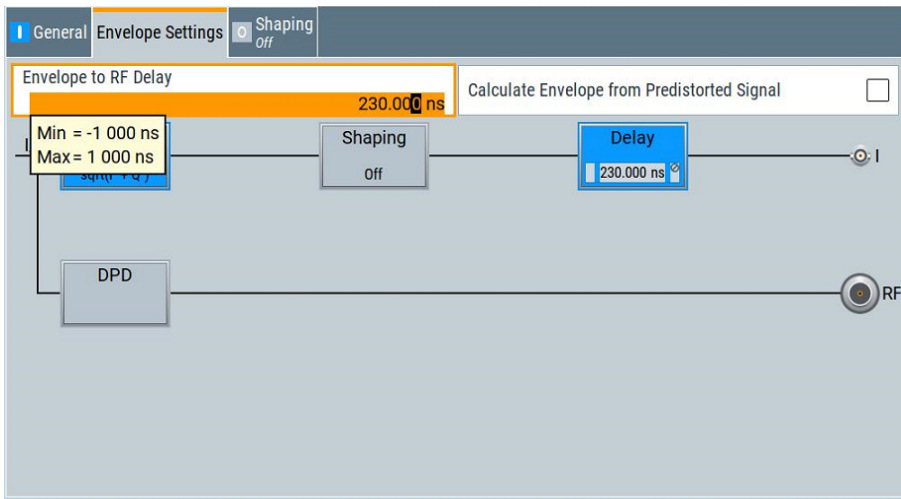

Fig.7 Setup for Envelope Delay

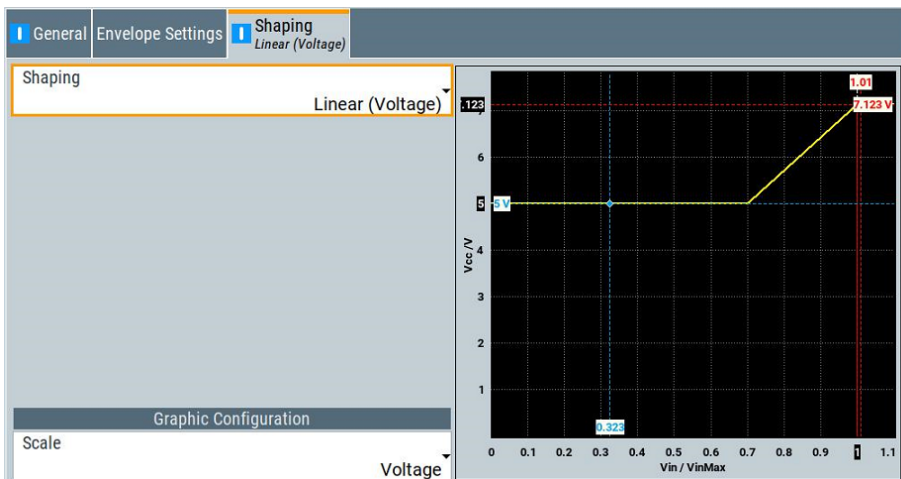

Fig.8 Setup for Shaping

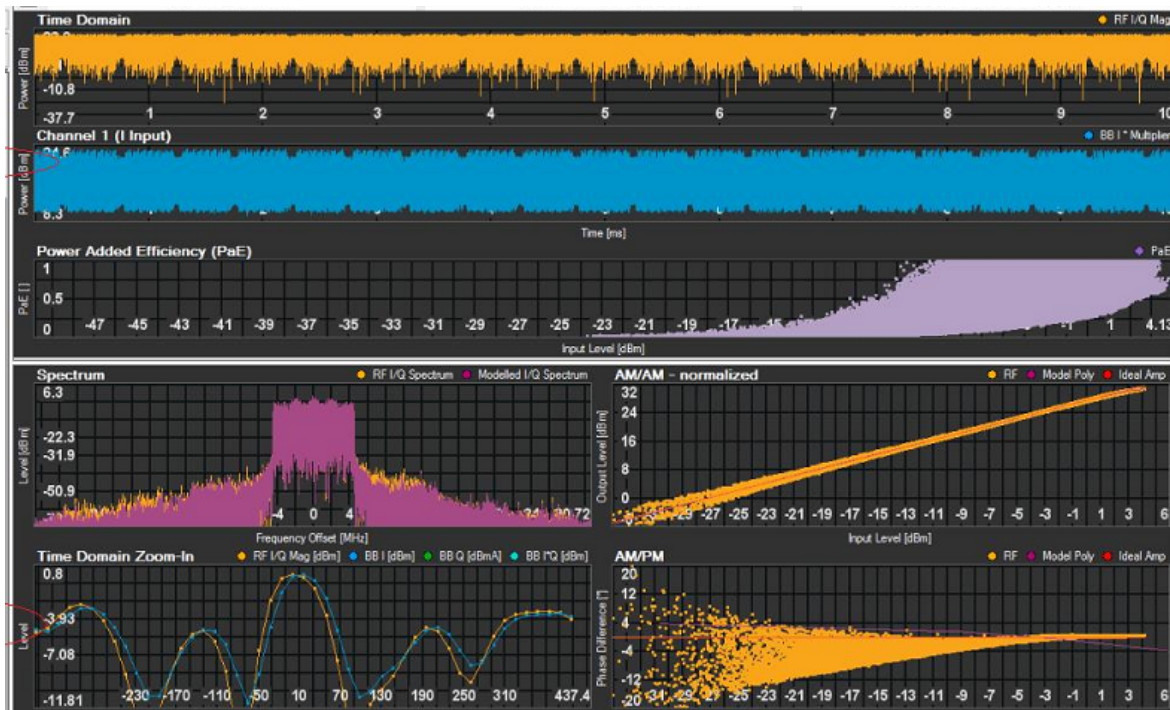

Fig.9 ET measurement results

5 Conclusion

ET technology is very effective to improve the PAE of PA, especially for those working in the high PAPR conditions. In this paper, the principle of ET technology is given, and the ET measurement system is designed based on R&S SMW200A vector signal generator and SMW vector signal analyzer. The measurement results show that the PAE of the PA with ET is improved by nearly 20% compared with that without ET.

Acknowledgement

The paper is supported by Shenzhen Strategic Emerging Industry Development Fund Project - Public service platform for 5G key components testing (20170921165224440).

References

- [1] Li Zhiqiang. (2017). Envelope Tracking System Performance Test based on Vector Signal Generator and Signal & Spectrum Analyzer. *China Integrated Circuit*. 5, pp. 66-69.
- [2] R&S SMW-K540, R&S SMW-K541 Envelope Tracking and AM/AM, AM/PM Predistortion User Manual.
- [3] R & S SM W 200A Vector Signal Generator User Manual.
- [4] Wang Lichun. (2018). Digital predistortion test scheme of broadband power amplifier, *Telecommunication network technology*. (2), pp. 87-90.
- [5] Kong Liang, He Yu. (2019). Research on digital predistortion model extraction based on systemvue[J]. *Electronics Quality*. (12), pp. 18-21, 26.
- [6] M.Hassan, Myoungbo Kwak. High Efficiency Envelope Tracking Power Amplifier with Very Low Quiescent Power for 20MHz LTE. (2011). *IEEE Radio Frequency Integrated Circuits Symposium*.
- [7] JIN Qian, RUAN Xinbo, REN Xiaoyong. (2017). Step-wave switched capacitor converter for compact design of envelope tracking power supply. *IEEE Transactions on Industrial Electronics*. 64(12), pp. 9587-9591.
- [8] Hao Meng. (2014). Analysis and design consideration of hybrid supply modulator for envelope tracking power

- amplifier. *Industrial Electronics and Applications (ICIEA)*. pp. 151-154.
- [9] Cao Tao, Liu Youjiang, Yang Chun. (2020). Circuits Optimization and System Linearization for High Efficiency and Wideband Envelope Tracking Architecture. *Journal of Electronics & Information Technology*. (3), pp. 787-794.
- [10] Qu Lixiang, Li Sizhen, Yu Kai. (2019). Three-level envelope modulator for envelope tracking power amplifier. *Microelectronic Technology*. (12), pp. 70-73, 82.
- [11] Hu Yun, Xue Hongxi. (2010). Study of envelope tracking power amplifier design. *Journal of Circuits and Systems*. (6), pp. 6-10.
- [12] Pan Xiaojun, Liu Huiyuan. (2019). A Dual-Mode Hybrid Envelope Tracking Supply Modulator for RFPA. *Journal of Fudan University (Natural Science)*.
- [13] Peng Lin, Zhang Guohao. (2019). Research progress of millimeter wave CMOS RF power amplifier for 5G applications. *Application of Electronic Technique*. (3), pp. 7-12, 18.
- [14] Jia Wenqiang, Yu Hongxi, Yang Fei. (2018). Design of a Broadband Doherty Amplifier Based on Envelope Tracking. *Telecommunication Engineering*. (12), pp. 118-121.

- [15] Ni Tao, Liu Falin. (2011). A Novel Digital Predistortion Model Based on Circuit Characteristic of Envelope Tracking Power Amplifier. (2), pp.117-120.

Author biographies



XING Rongxin, received master's degree from Beihang University in 2004. Now he works for China Electronics Standardization Institute and Shenzhen CESI Information Technology Co. His main research interest is microwave components measurement and calibration.

Email: 15901519692@139.cm



WANG Han, received master's degree from Beijing University. Now she works for China Electronics Standardization Institute and Shenzhen CESI Information Technology Co. Her main research interest is integrated circuit testing and measurement of conductor instruments and equipment.

Email: wanghan@cesi.cn



Copyright: © 2020 by the authors. This article is licensed under a Creative Commons Attribution 4.0 International License (CC BY) license (<https://creativecommons.org/licenses/by/4.0/>).